

primus®

GET AHEAD IN LAUNDRY+



T25 | T35 TUMBLE DRYER



RADIAL AIRFLOW
For maximal heat transfer, low energy consumption and short drying time



ECO VERSION
All dryers are available with reduced kW heating element



CLOUD - BASED PLATFORM
to easily monitor your laundry everywhere and at any time



EXTRA LARGE DOOR OPENING
For easy loading and unloading



IMPROVED DURABILITY
for your peace of mind with a 3 - year warranty

FEATURES & BENEFITS

Features

- Standard galvanized drum with large diameter
- Large door opening for easy loading & unloading
- Self cleaning lint screen

Options

- Coin operated
- Stainless steel front
- Reversing drum and radial airflow
- Double door glass and insulation
- Residual moisture control Sensodry:
 - safe drying of delicate linen
 - humidity detection in %
 - ideal in combination with SoftWash®
 - ideal for dry cleaners, fire depts
 - available on Easy and Full Control
- WiFi kit - to order through Accessories

Control

- Easy - To - Use Microprocessor (ECT) - intuitive control with simple selection of 3 programs
- Full Control Programmer (FCT) - fully programmable timer with possibility of residual moisture control

SPECIFICATIONS

TYPE		T25	T35
CAPACITY			
Capacity 1:18	kg (lb)	25(55)	38(84)
Capacity 1:22	kg (lb)	24(56)	31(68)
Drum volume	l	530	680
Drum diameter	mm	Ø 930	Ø 930
AIRFLOW			
	m³/h	950	1200
DRYING AVERAGE			
	l/min.	0,384	0,560
MOTORS			
Fan	kW	0,55	0,55
Drive	kW	0,25	0,25
GAS HEATING			
Gas connection	NPT	3/4"	3/4"
Electrical connection		3x220 - 240V 50Hz, 1x220 - 240V 50Hz, 3x380 - 415V 50Hz	
Energy	kW	33/39	46/50
	kBTU/h	112,6/133,1	157,9/170,6
STEAM HEATING			
Steam connection	inch	3/4"	3/4"
Electrical connection		1x208V - 240V 60Hz (3x380V - 415V 50/60Hz)	
Steam output *	kW	27 - 36,2	39,3 - 52,7
Steam pressure	bar	7 - 10	7 - 10
ELECTRICAL HEATING			
Electrical connection		3x380V - 415V 50/60Hz, 3x480V 60Hz	
Energy	kW	30/36	36/48
EXHAUST			
	mm	200	200
DIMENSIONS			
Size HxWxD	mm	1975x965x1270	1975x965x1490
Net weight	kg	275	305
TRANSPORT DATA			
Packed HxWxD	mm	2075x1040x1320	2075x1040x1540
Gross weight	kg	300	330

+ = available, The data concerning dimensions of machines include all extended parts

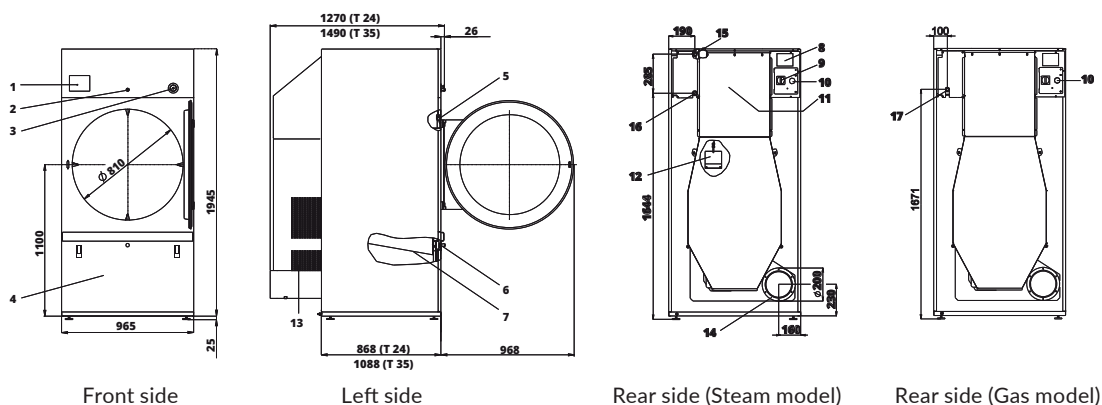

1. Programmer
2. Lock of the control panel
3. Emergency stop button
4. Lint screen cover
5. Door lock microswitch
6. Lint cover microswitch

7. Lint screen
8. Name plate
9. Main switch
10. Main power supply
11. Heating chamber
12. Airflow switch

13. Suction
14. Exhaust piping
15. Steam supply
16. Condense drain
17. Gas connection